



Benha University

Dr. Mohamed Ahmed Ebrahim



Undergraduate Course

Solar Cells Fundamental

Dr. Mohamed Ahmed Ebrahim

E-mail: mohamedahmed_en@yahoo.com

Web site: <http://bu.edu.eg/staff/mohamedmohamed033>



Dr. Mohamed Ahmed Ebrahim



Lecture (3)



Dr. Mohamed Ahmed Ebrahim

Last Lecture Summary (Solar PV)

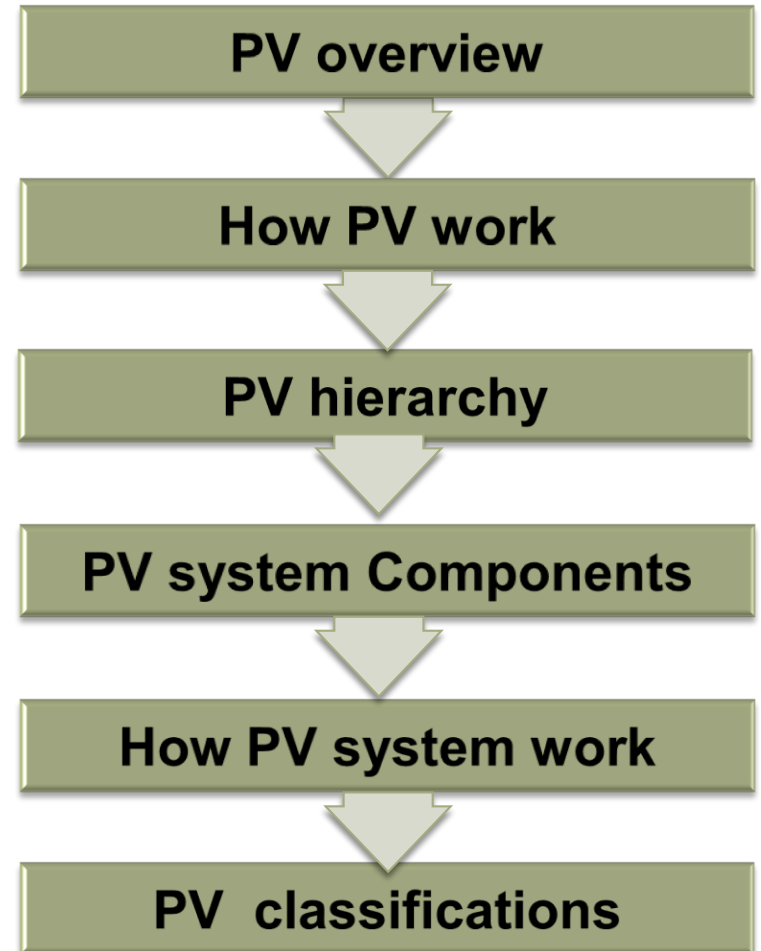

5. Photovoltaic System Components

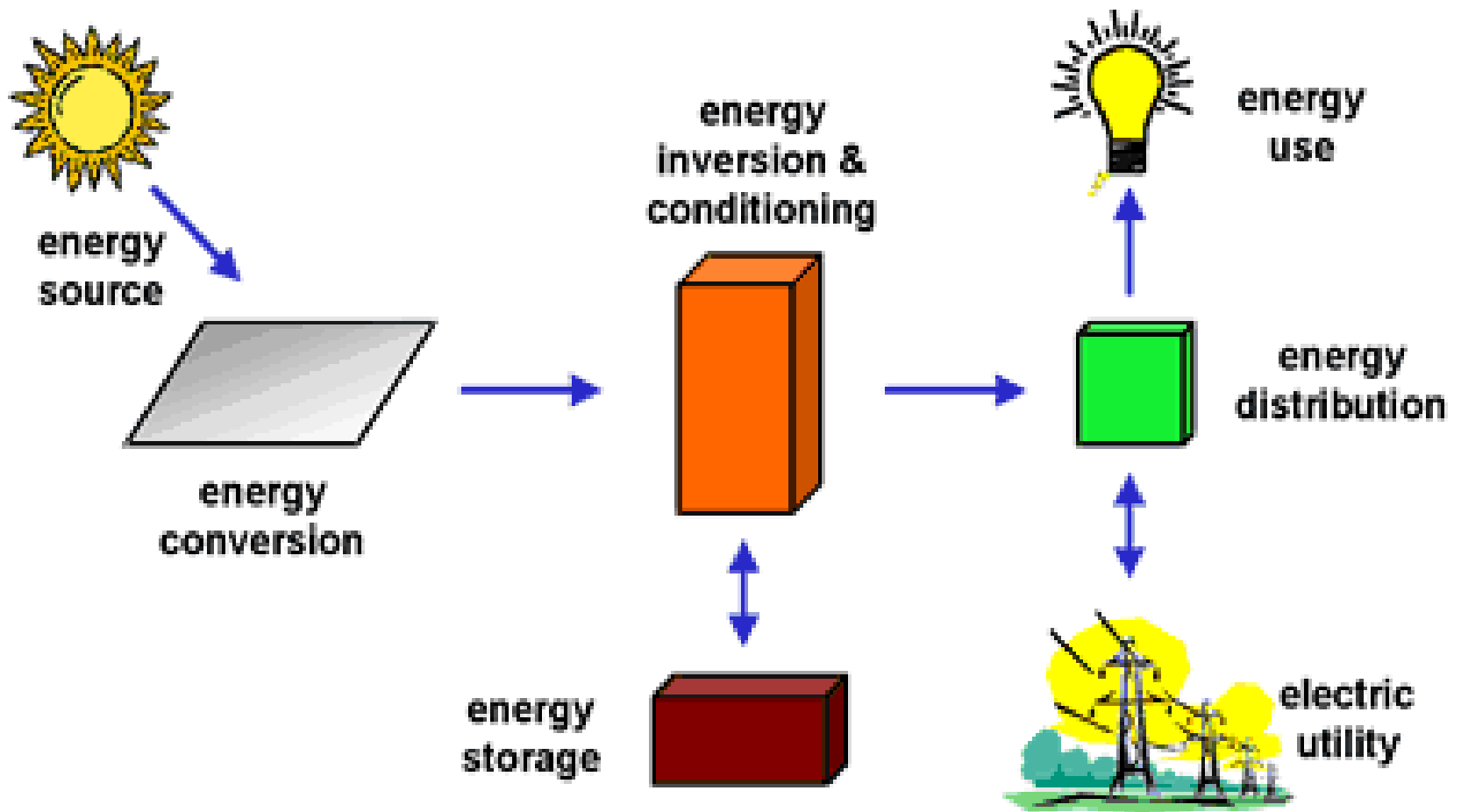

How a PV System Works

- PV systems are like any other electrical power generating systems, just the equipment used is different than that used for conventional electromechanical generating systems.
- Depending on the functional and operational requirements of the system, the specific components required, and may include major components:
 - * DC-AC power inverter.
 - * battery bank.
 - * system and battery controller,
 - * auxiliary energy sources.

- * specified electrical load (appliances).
- * an assortment of balance of system (BOS) hardware, including wiring, over current, surge protection and disconnect devices, and other power processing equipment.

6. PV Technology Classification

A- Silicon Crystalline Technology

→ Mono Crystalline PV Cells

→ Multi Crystalline PV Cells



b- Thin Film Technology

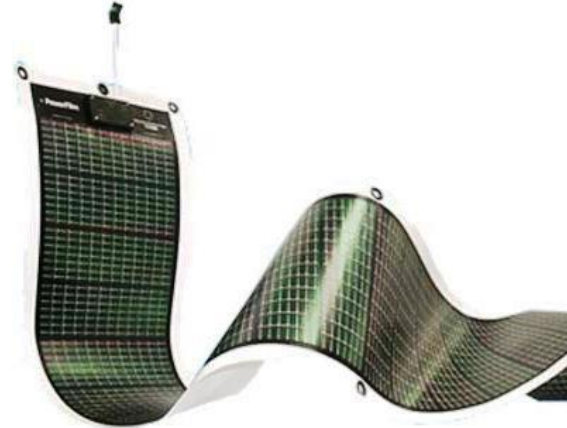

→ Amorphous Silicon PV Cells

→ Poly Crystalline PV Cells
(Non-Silicon based)



A. Silicon Crystalline Technology

- Currently makes up 86% of PV market.
- Very stable with module efficiencies 10-16%.

#	Mono crystalline PV Cells	Multi Crystalline PV Cells
Manufacture	Made using saw-cut from single cylindrical crystal	Caste from ingot of melted and recrystallized silicon
Efficiency	Operating efficiency up to 15%	Cell efficiency ~12%
Production	Most expensive to produce	Less expensive to make than single crystalline modules
Module	Circular (square-round) cell creates wasted space on module	Square shape cells fit into module efficiently using the entire space
Shape		

Dr. Mohamed Ahmed Ebrahim

B. Thin Film Technology

- Silicon deposited in a continuous on a base material such as glass, metal or polymers.
- Thin-film crystalline solar cell consists of layers about $10\mu\text{m}$ thick compared with $200\text{-}300\mu\text{m}$ layers for crystalline silicon cells.



Advantage

- Low cost substrate and fabrication process.

Disadvantage

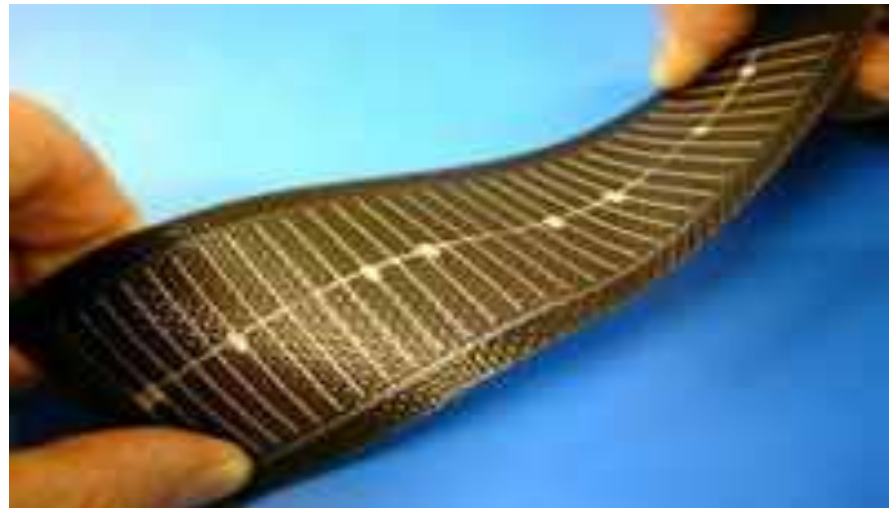
- Not very stable.



#	Amorphous Silicon PV Cells	Poly Crystalline PV Cells
Technology	The most advanced of thin film technologies	high absorption coefficient
Efficiency	Operating efficiency ~6%	High efficiency levels
	Makes up about 13% of PV market	
Advantage	Mature manufacturing technologies available	<ul style="list-style-type: none"> • 18% laboratory efficiency • >11% module efficiency
Disadvantage	Initial 20-40% loss in efficiency	<ul style="list-style-type: none"> • Immature manufacturing process • Slow vacuum process
Shape		

Activity

What is the advantages and disadvantages of solar photovoltaic?

Solar Photovoltaic's

Dr. Mohamed Ahmed Ebrahim

7. Criteria to Select the Correct PV Module

- **Practical Criteria:**
 1. Size.
 2. Voltage.
 3. Availability.
 4. Warranty.
 5. Mounting Characteristics.
 6. Cost (per watt)

7. Solar PV energy conversion

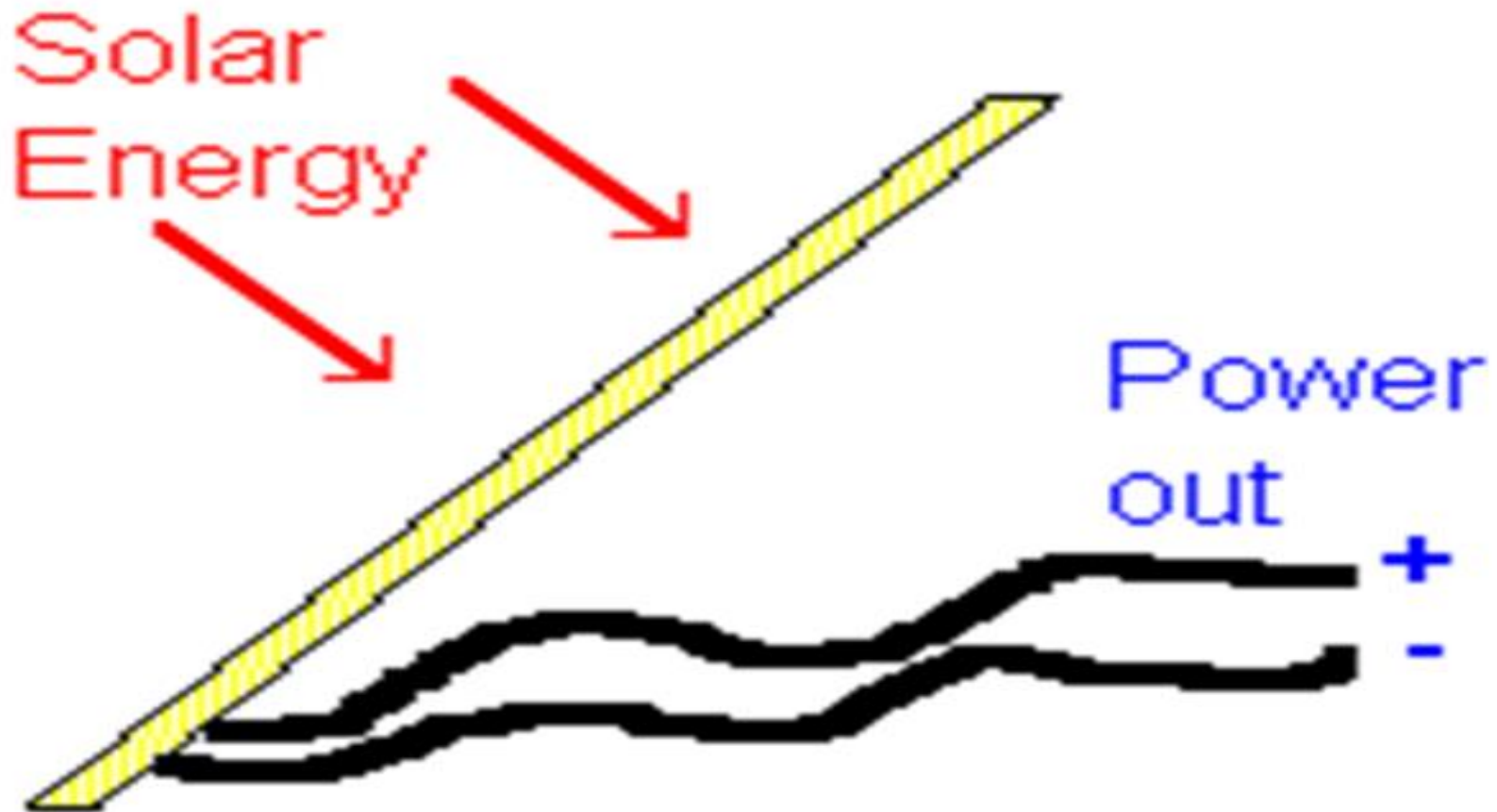

- The conversion efficiency of a PV cell is the proportion of sunlight energy that the cell converts into electrical energy.
- This is very important because improving this efficiency is vital to making PV energy competitive with more traditional sources of energy, such as fossil fuels.
- The first PV cells were converting light to electricity at 1 to 2 percent efficiency.
- Today's PV devices convert up to 17 percent of the radiant energy that strikes them into electric energy.

8. How PV cells are Made?

- a) The process of fabricating conventional single- and polycrystalline silicon PV cells begins with very pure semiconductor-grade.
- b) The polysilicon is then heated to melting temperature, and trace amounts of boron are added to the melt to create a P-type semiconductor material.
- c) Then, an ingot, or block of silicon is formed.
- d) Individual wafers are then sliced from the ingots using wire saws and then subjected to a surface etching process.
- e) After the wafers are cleaned, they are placed in a phosphorus diffusion furnace, creating a thin N-type semiconductor layer around the entire outer surface of the cell.

- e) Then, an anti-reflective coating is applied to the top surface of the cell, and electrical contacts are imprinted on the top (negative) surface of the cell.
- f) An aluminized conductive material is deposited on the back (positive) surface of each cell, restoring the P-type properties of the back surface by displacing the diffused phosphorus layer.
- g) Each cell is then electrically tested, sorted based on current output, and electrically connected to other cells to form cell circuits for assembly in **PV modules**.

PV Module Anatomy

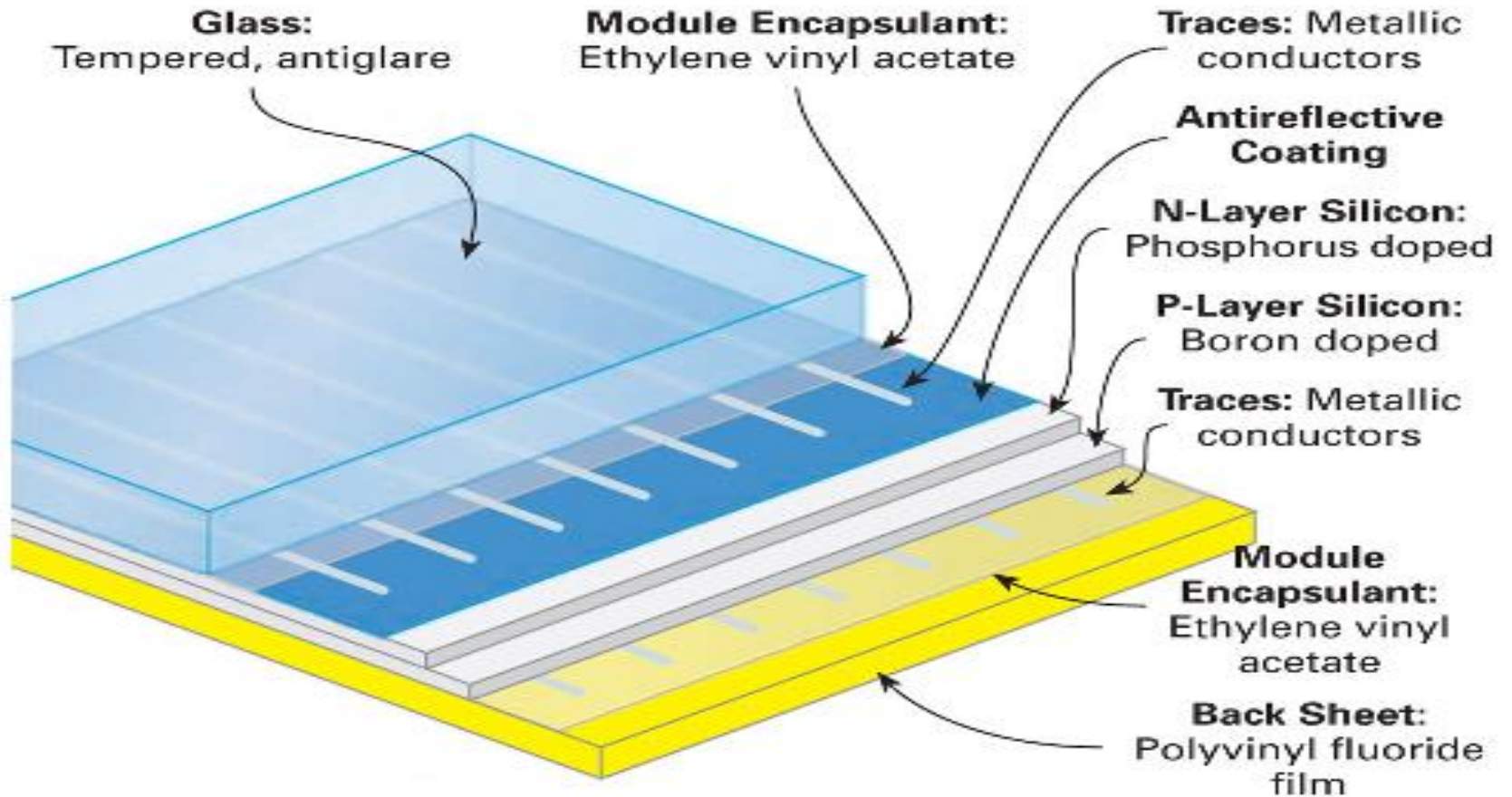

9. Solar PV Characteristics

Current-Voltage curve (I-V)

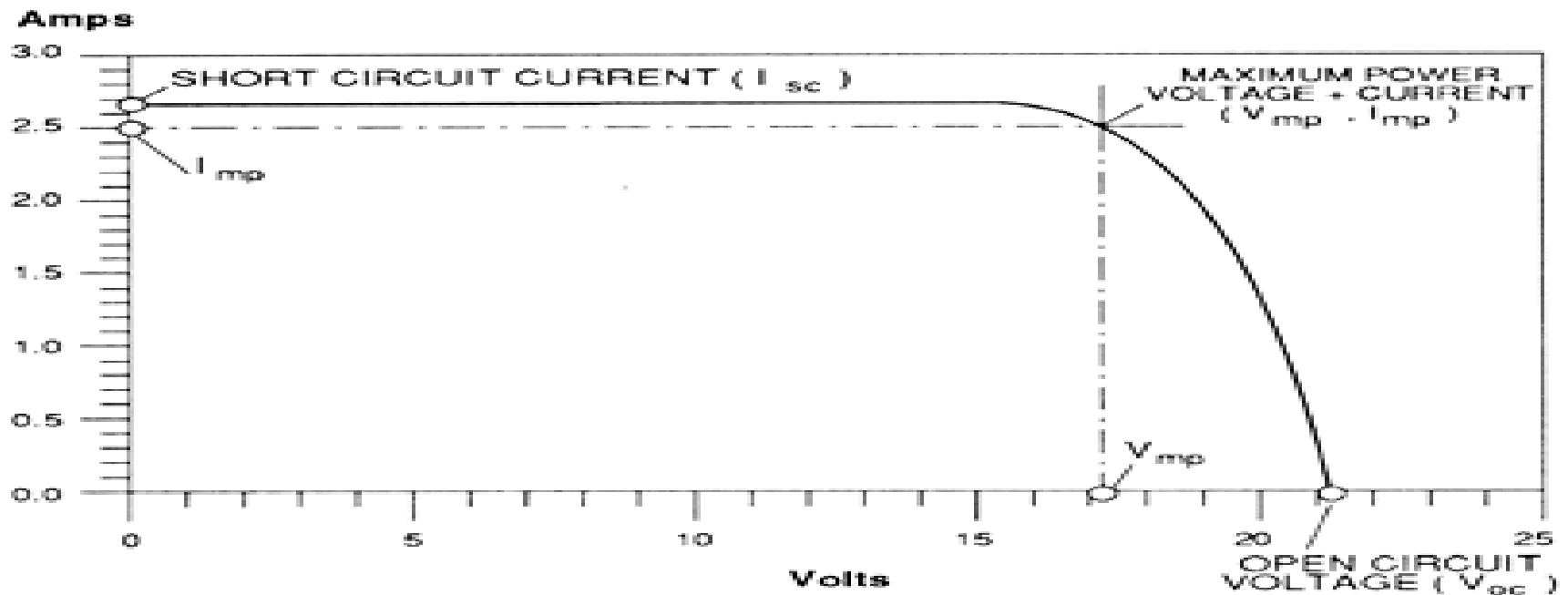

- A current-voltage (I-V) curve shows the possible combinations of current and voltage output of a photovoltaic (PV) device.

- A PV module produces its maximum current when there is no resistance in the circuit.
- This maximum current is known as the short circuit current (I_{sc}).
- When the module is shorted, the voltage in the circuit is zero.
- the maximum voltage occurs when there is a break in the circuit. This is called the open circuit voltage (V_{oc}).
- Under this condition the resistance is infinitely high and there is no current, since the circuit is incomplete.

The effects of temperature on the I-V curve

- The effects of temperature on the I-V curve of a PV cell. I_{SC} increases slightly with temperature by about $6\mu\text{A}$ per $^{\circ}\text{C}$ for 1cm^2 of cell, this is so small that it is normally ignored.
- a more significant effect is the temperature dependence of voltage which decreases with increasing temperature.
- Typically the voltage will decrease by 2.3mV per $^{\circ}\text{C}$ per cell.

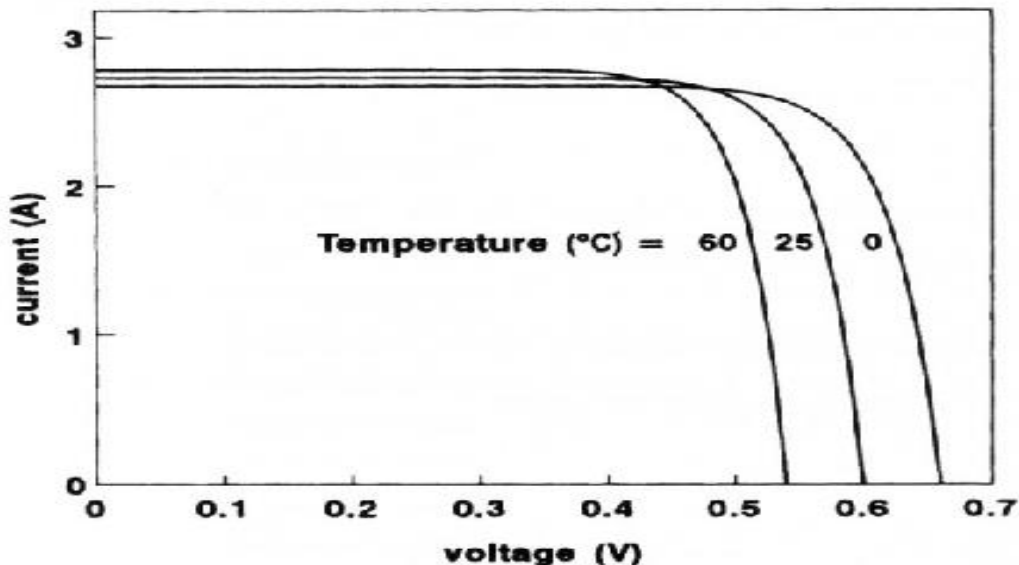

The effects of Shading on the I-V curve

- temperature increases, the voltage decreases substantially while the current undergoes insignificant increase.
- As a result, the power decreases with increasing temperature.

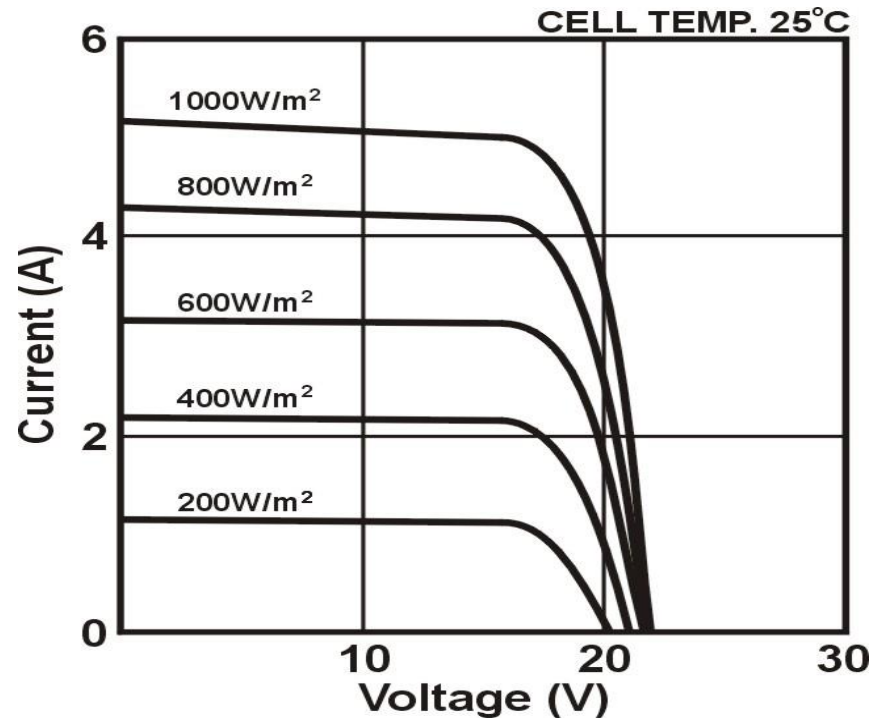

Solar PV Equivalent circuit

- Equivalent circuit models define the entire I-V curve of a cell, module, or array as a continuous function for a given set of operating conditions.
- One basic equivalent circuit model in common use is the single diode model.

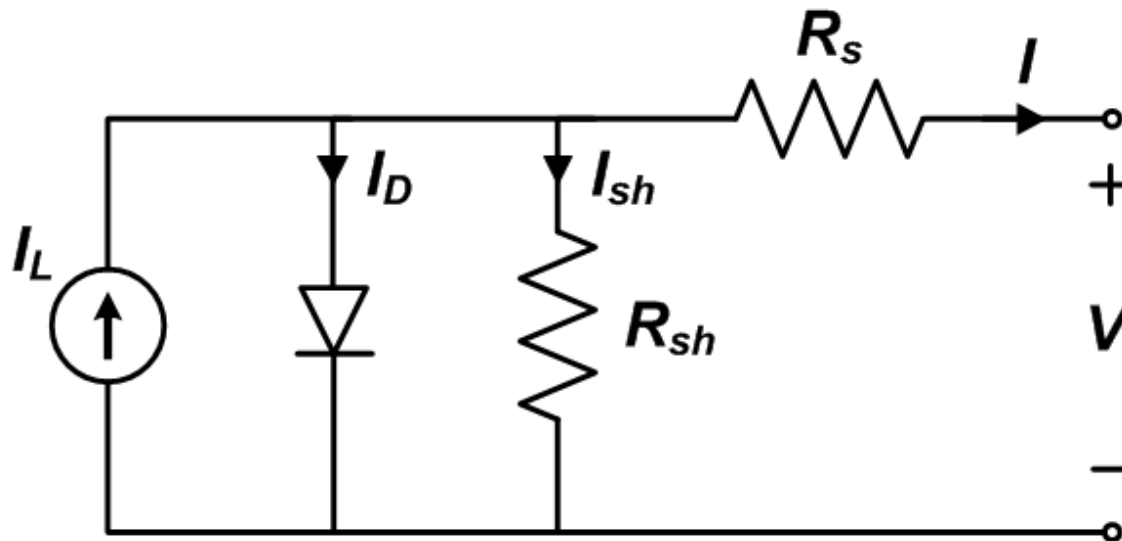

From the equivalent circuit it is evident that the current produced by the solar cell is equal to that produced by the current source, minus that which flows through the diode, minus that which flows through the shunt resistor

$$I = I_L - I_D - I_{SH}$$

where

I = output current (ampere).

I_L = photo generated current (ampere)

I_D = diode current (ampere)

I_{SH} = shunt current (ampere).

10. PV wiring

a) **Wiring in parallel circuit**

- **Parallel circuits** have multiple paths for the current to move along. If an item in the circuit is broken, current will continue to move along the other paths, while ignoring the broken one. This type of circuit is used for most household electrical wiring.
- When wiring solar panels in parallel, the amperage (current) is additive, but the voltage remains the same.

PV Wiring in parallel

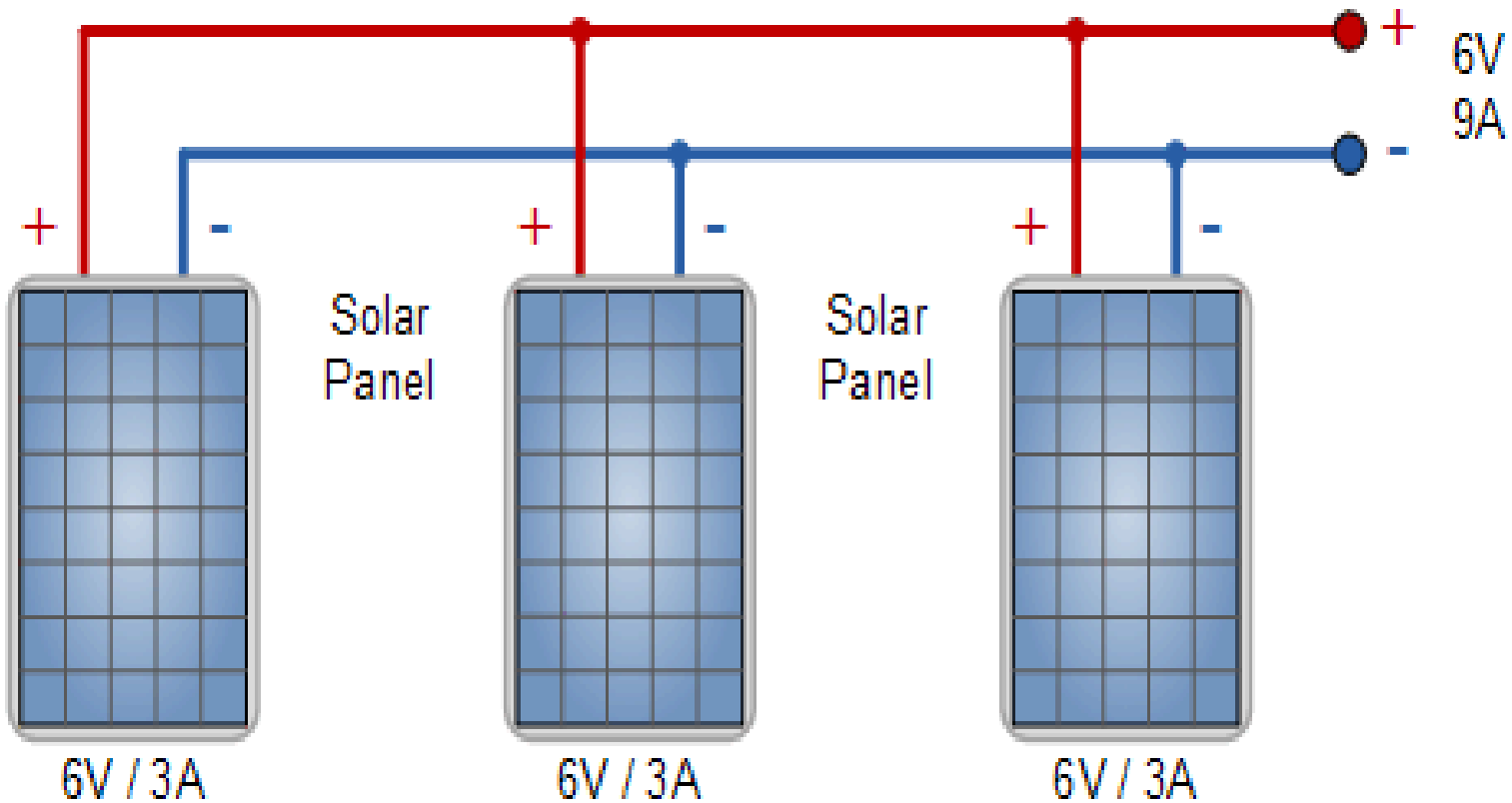

b) **Wiring in Series circuit**

- **Series circuits** have only one path for current to travel along. Therefore, all the current in the circuit must flow through all the loads.
- A series circuit is a continuous, closed loop breaking the circuit at any point stops the entire series from operating.
- When wiring solar panels in a series, the voltage is additive, but the amperage remains the same.

PV Wiring in Series

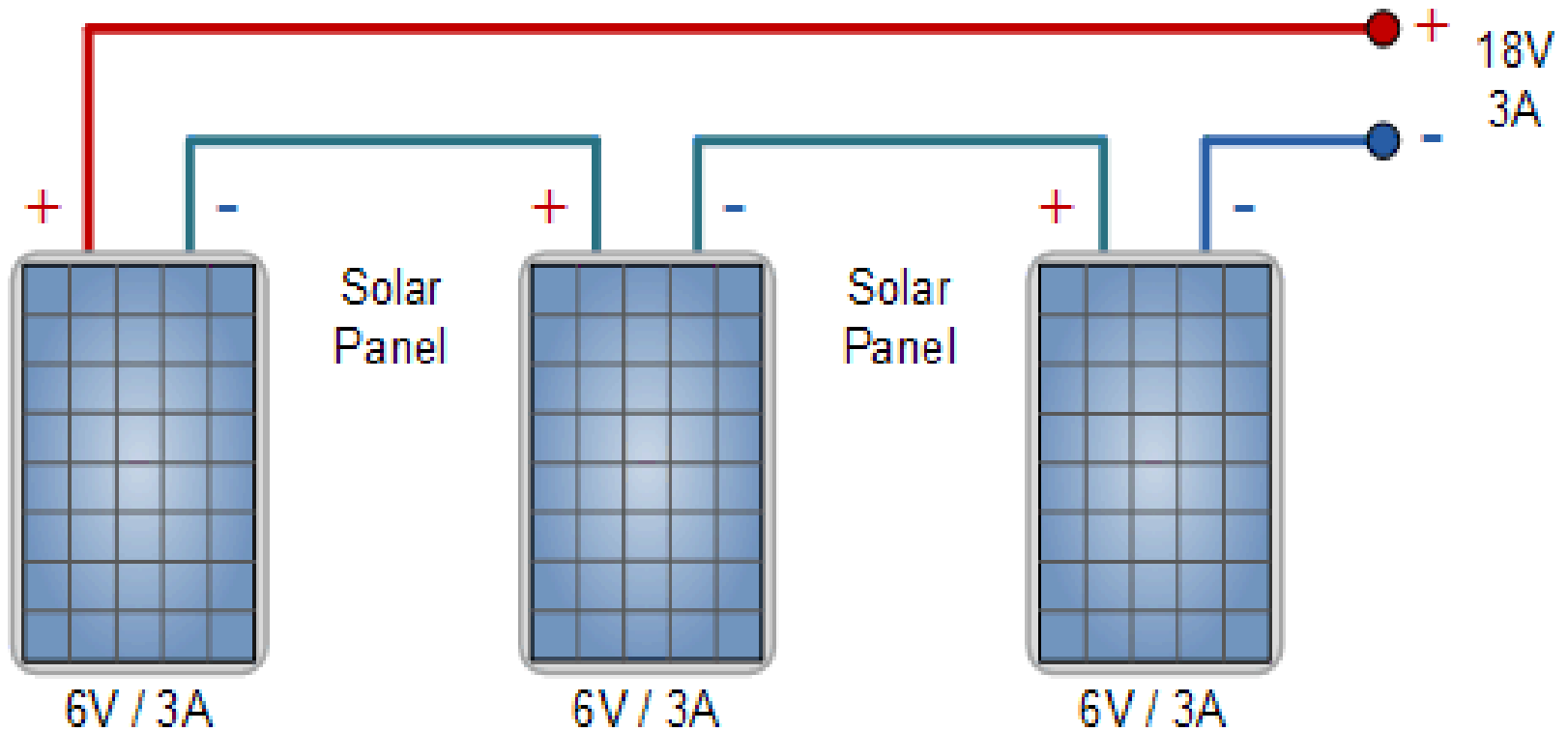

Should wire PV system in Parallel or in Series?

- The capacity of a PV solar panel to produce energy is measured in watts, which is calculated by multiplying a solar panel's **voltage** by the **amps** of current it produces.
- When a PV installer builds a solar energy system, they need to find the right balance of voltage and amps to ensure that the system performs well.
- Depending on the equipment that the system uses and the size of the system, solar installer may decide to wire the solar panels in series, in parallel, or in a combination of the two systems.

11. PV Systems classified according to

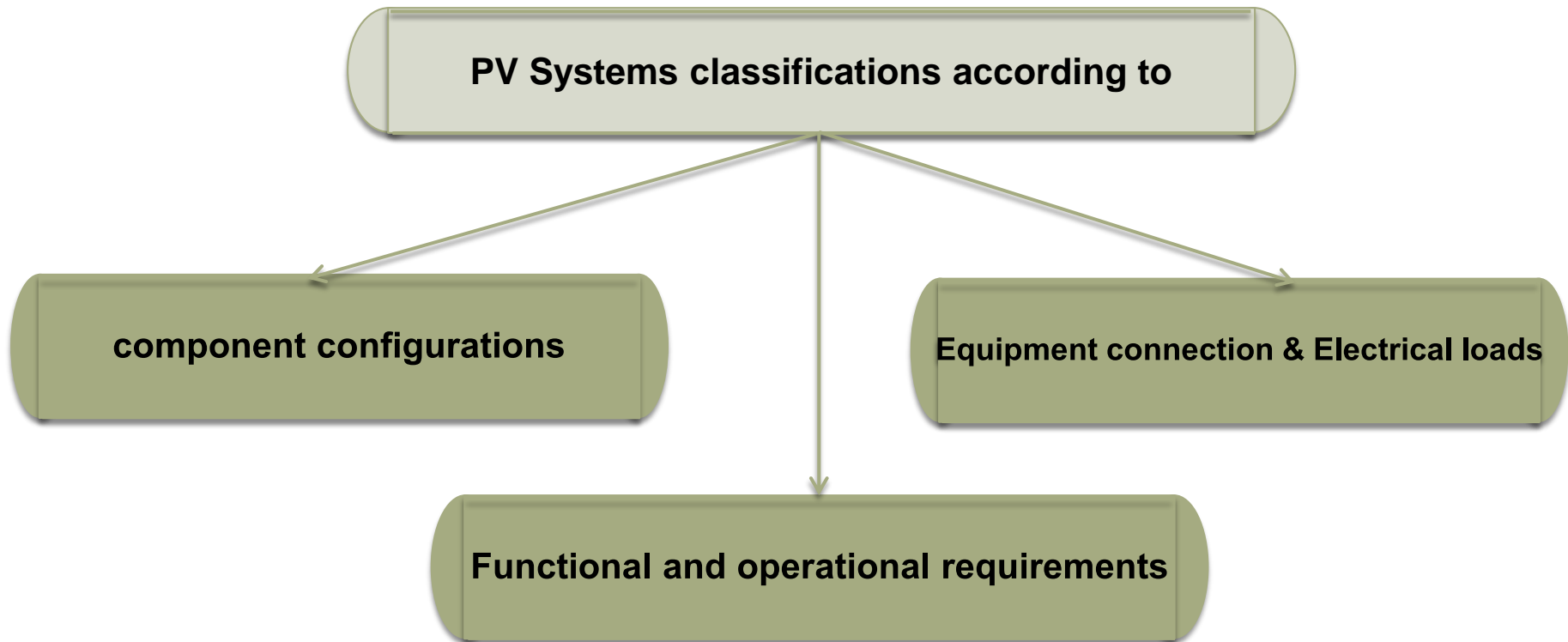



Photovoltaic systems can be designed to provide DC or/and AC power service, can operate interconnected with/or independent of the utility grid, and can be connected with other energy sources and energy storage.

12. PV system principle classifications

1. **Central power station system:**

- These are conceptually similar to any other conventional power station. They feed power to the grid to meet day time peak load.
- The capital costs are high.

2. **Distributed systems**

- This system is much more successful and unique. it can be further classified into three types:
 - * grid-connected (utility interactive systems).
 - * stand-alone systems.
 - * Hybrid solar PV systems.

1. Stand-alone Systems

- Stand alone solar system the solar panels are used to charge a bank of batteries.
- These batteries store the power produced by the solar panels and then the electrical loads draw their electricity from these batteries.
- Stand alone solar power systems have been used for a long time in areas where no public grid is available.
- Stand-alone systems are more expensive than grid connect systems because batteries are very expensive

Diagram of stand-alone PV system with battery storage powering DC and AC loads

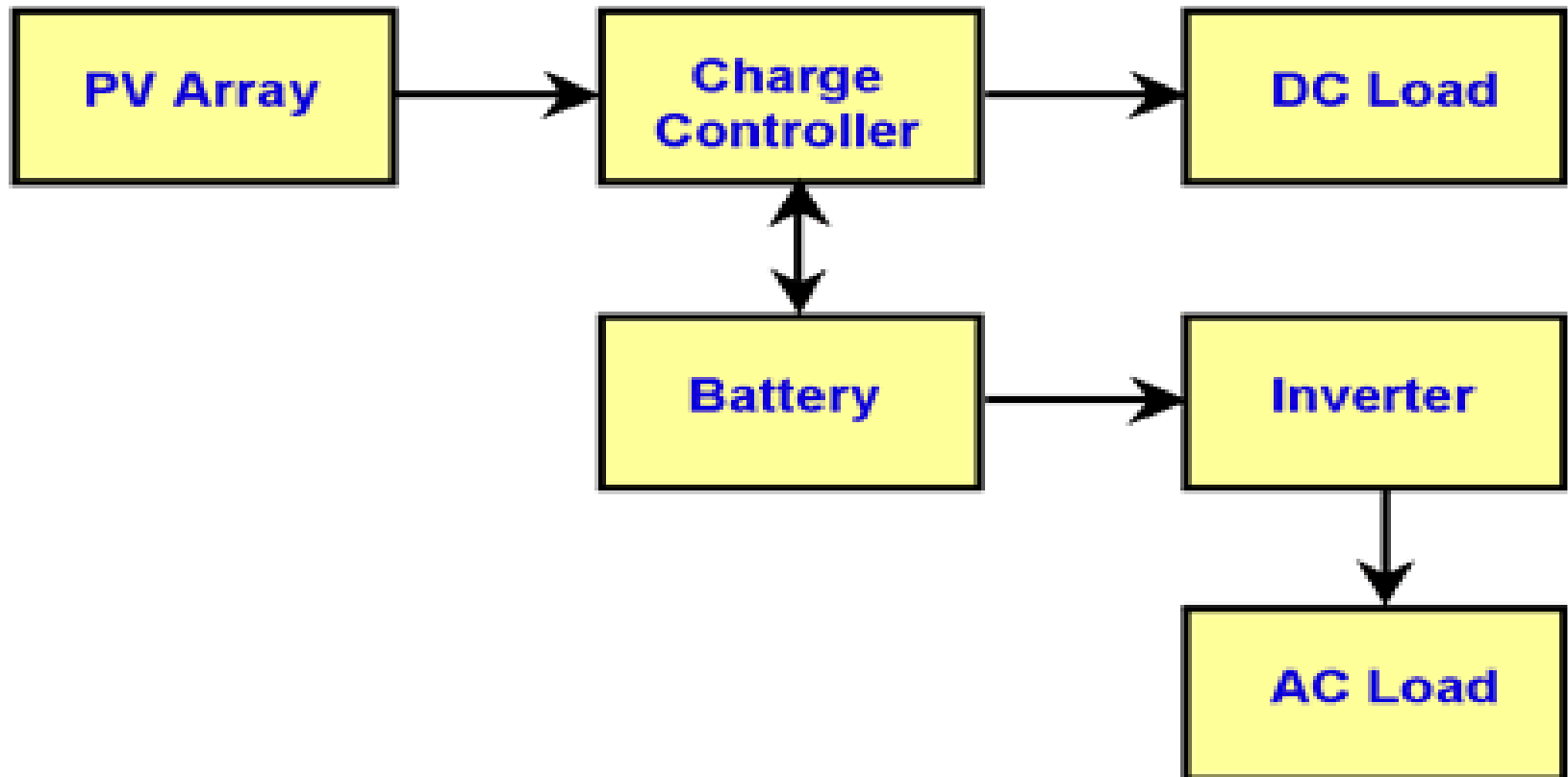

2. Grid Connected System

- A grid connect system is one that works in with the local utility grid so that when solar panels produce more solar electricity than house is using the surplus power is fed into the grid.
- With a grid connect solar power system when your house requires more power than what your solar panels are producing then the balance of your electricity is supplied by the utility grid.
- the real growth in solar power systems in the last 5 years has been in grid connect systems. Because stand-alone systems are more expensive than grid connect systems because batteries are very expensive.

Diagram of grid-connected photovoltaic system

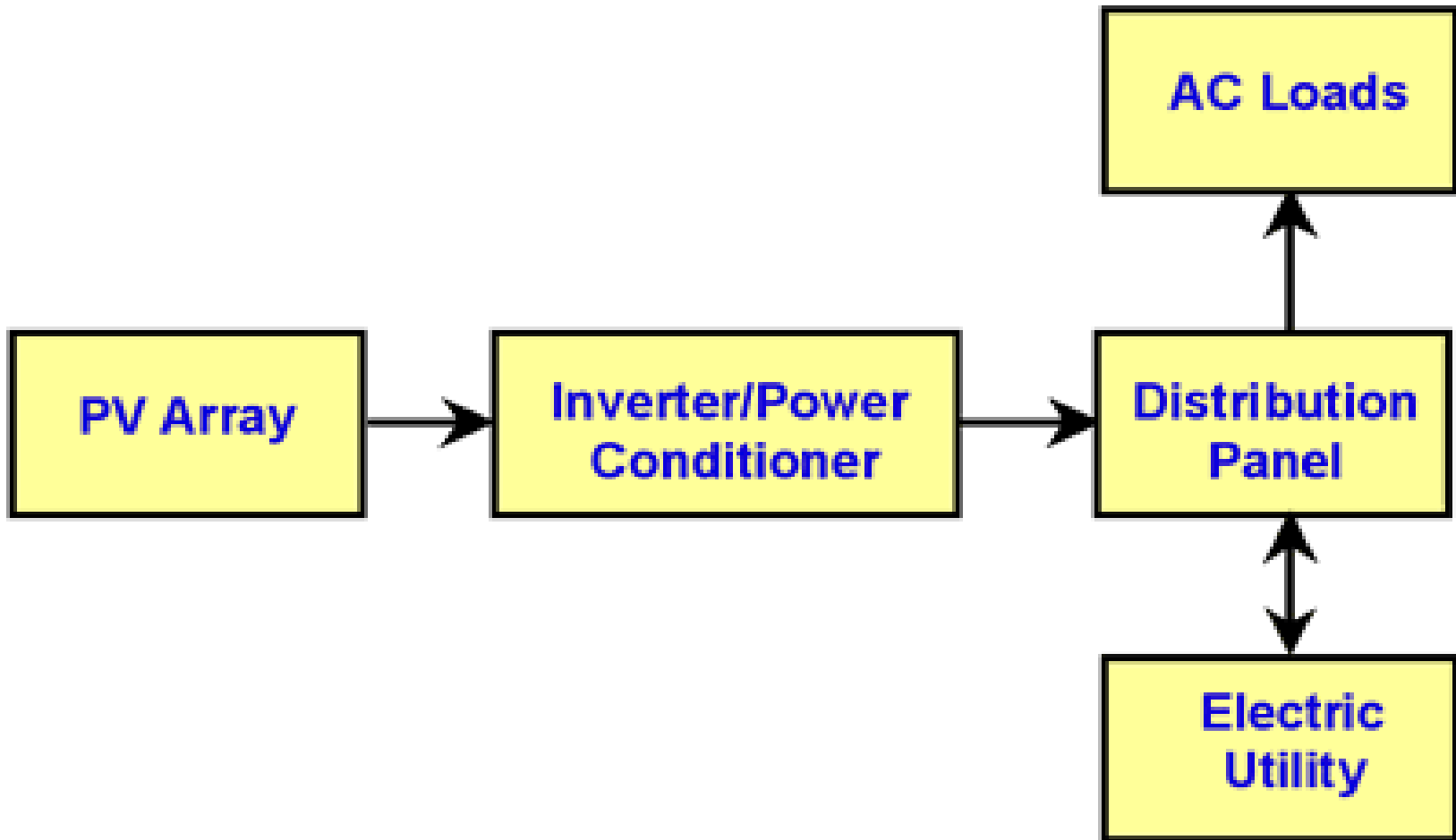

3. PV Hybrid System

- These system are meant for low energy consumer devices, basically designed for indoor applications
- These types of systems may be powered by a PV array only, or may use wind, an engine-generator or utility power as an auxiliary power source in what is called a PV-Hybrid System.

Diagram of Hybrid photovoltaic system

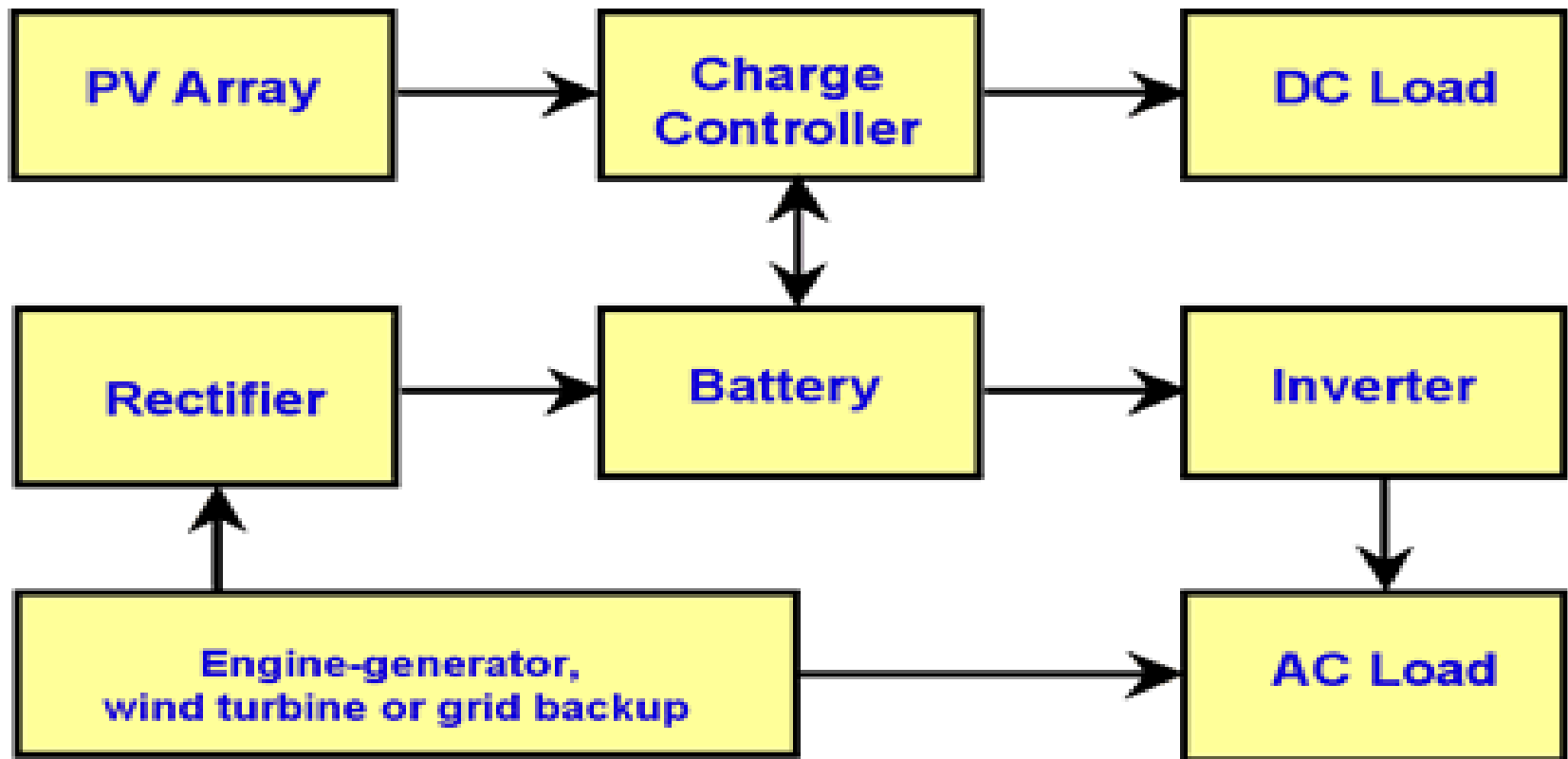

13. Why Are Batteries Used in Some PV Systems?

- Batteries are often used in PV systems for the purpose of storing energy produced by the PV array during the day, and to supply it to electrical loads as needed (during the night and periods of cloudy weather).
- Batteries are used in PV systems are to operate the PV array near its maximum power point, to power electrical loads at stable voltages, and to supply surge currents to electrical loads and inverters.
- In most cases, a battery charge controller is used in these systems to protect the battery from overcharge and over discharge.

How is a solar PV system installed?

- Solar panels can be mounted on un-shaded roofs, walls, and ground using mounting system.
- DC cables connect panels in series (strings).
- These strings then feed back to the inverter usually located inside the building as close to the solar panels as possible.
- Every kW of electricity will be recorded.
- A 4 kW domestic PV system will usually take one day to install.

14. Advantages & Disadvantages of solar PV Systems

1. Advantages

- It converts the solar energy directly into electrical energy without going through thermal mechanical link.
- It has no moving parts.
- Solar PV systems are reliable, modular, durable, and generally maintenance free.
- These systems are quiet and compatible with almost all environments, expected life span of 20 years or more.
- It can be located at the place of use and hence no distribution network is required.

2. Disadvantages

- The costs of solar cells are high, making them economically uncompetitive with other conventional power source.
- The efficiency of solar cells are low.
- Large number of solar cell modules are required to generate power.
- Some kind of electrical energy storage is required, which makes the whole system more expensive.

15. Solar PV Applications

- **Grid interactive PV power generation.**
- **Water pumping** for the purpose of drinking or for irrigation during the sunshine hours..
- **Lighting** is the second most important application of stand alone system.
- **Medical Refrigeration** of life saving drugs.
- **Village power** solar PV power can meet low energy demands of many remote, small, isolated villages.
- **Telecommunication and signaling applications** such as local telephone exchange, radio, and TV broadcasting.

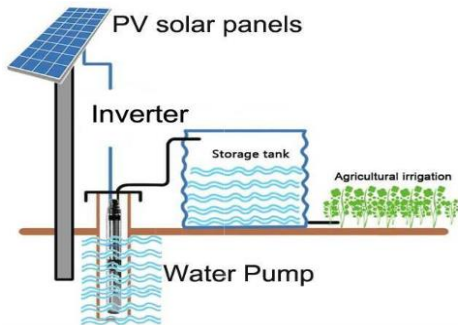
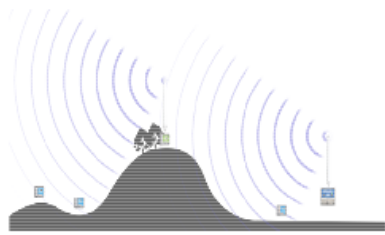

**Communi-
cations**

Lighting

**Signal
System**

**PV
Solar**

**Charging
Vehicle
Batteries**

**Water
Pumping**

**Refriger-
ation**



Dr. Mohamed Ahmed Ebrahim